













Safety Notes

IMPORTANT:

Please read the following precautions carefully before using this equipment.

-  This unit contains high voltage circuits that may expose you to the danger of electric shock.
-  Means for disconnection must be incorporated in accordance with the wiring rules.
-  **Do not** open the enclosure without isolating the signal and supply sources. Ensure that these sources have been isolated for at least 5 minutes before entering the enclosure.
-  **Do not** power the unit outside of the values stated on the rating label.
-  **Do not** use damaged or frayed cables.
-  **Do not** dismantle or modify this equipment.
-  **Never** insert fingers into mechanisms without turning the power supply off first.
-  **Do not** mount the unit to unstable, irregular or non-vertical surfaces.
-  **Do not** place heavy objects on top of the unit.
-  **Do not** attempt to place items (such as screwdrivers) into the moving parts of the pump head.
-  **Always** ensure that care is taken when handling chemicals.
-  **Do not** discard the manual, this must be retained.

This unit must be installed by suitably qualified personnel in accordance with local regulations, or in the absence of local regulations, installed in accordance with the applicable requirements in the National Electrical Code, NFPA 70, Canadian Electrical Code (CEC), Part 1, CSA C22.1, and Standard for Ventilation Control and Fire Protection of Commercial Cooking Operations, NFPA 96.

This appliance can be used by children age from 8 years and above and persons with reduced physical, sensory or mental capabilities or lack of experience and knowledge if they have been given supervision or instruction concerning use of the appliance in a safe way and understand the hazards involved. Children shall not play with the appliance. Cleaning and user maintenance shall not be made by children without supervision.

If the supply cord is damaged, it must be replaced by the manufacturer, its service agent or similarly qualified persons in order to avoid hazard.

Before Installation

Ensure you have checked all parts required are present and inspect for any damage before installation. In the unlikely event your items are faulty, **DO NOT** install faulty or damaged parts as this is unsafe and will void any warranty. Please return to your distributor in the original delivery condition including any packaging. This unit is **ONLY** to be installed by a suitably qualified person complying with local regulations.

Peristaltic tubing
5mm Silicone
inc: Compression
fit connectors
× 1 Silicone Grease
5ml (for peristaltic
tubing)

Ceramic Weight
and foot filter
× 1

Pipe Injector
× 1

Polyethylene
Tubing
3000mm × 2

Fixings Pack:
Screws × 4 Wall
plugs × 4



Installation

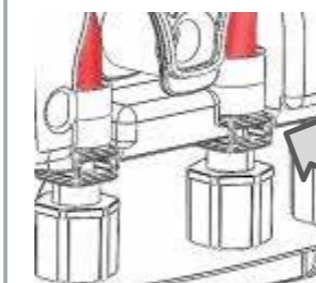
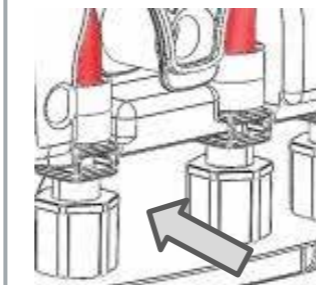
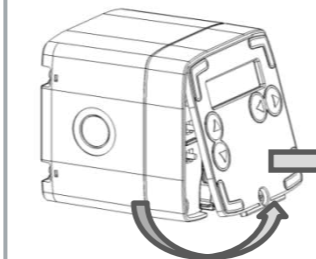
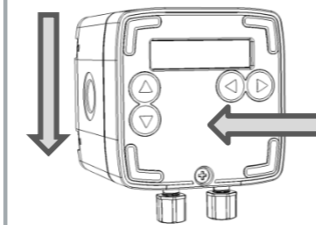
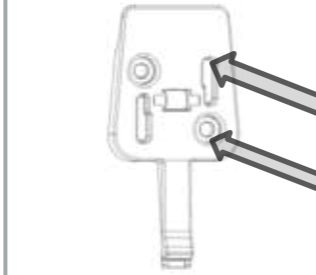

Mounting and connection

Step 1: Using the wall plugs and screws specified for this unit, fix the mounting bracket to the wall. There is an embedded spirit level to aid with this part of the installation.

Step 2: Mount the unit to the wall by hooking it onto the wall bracket. Press down firmly and you will hear a click sound when the unit is secure.

Step 3: Ensure there is no power to the unit, remove the front cover by turning removing the screw anti-clockwise and pulling the front cover towards you as shown.

Step 4: Insert one end of the tube ensuring that it is slotted into the body of the enclosure as shown.

IMPORTANT INFORMATION: Silicone grease provided must be applied to the tube and the pump & rotor assembly before the tube is inserted. Failure to apply the grease will affect the pump performance during operation.

Step 5: Now by manually rotating the pump head, feed the tube into the unit as shown. **IMPORTANT** to aid prolonging tube life and efficient running of both mains and battery powered models. Please use the **Silicone Grease** (supplied) on the outer of the tube. Spread liberally to the outside of the tube to help ease installation, this will also aid continuous smooth operation and help prevent any potential snagging.

Step 6: Now insert the other end of the tube ensuring that it is slotted into the body of the enclosure as shown.

IMPORTANT INFORMATION: BioBax accepts no responsibility and/or damages caused to either the product or premises if the installation process is not complied with in full.

Installing the Pipe Injector

Step 1: Drill a 14mm hole in the top of your intended waste pipe.

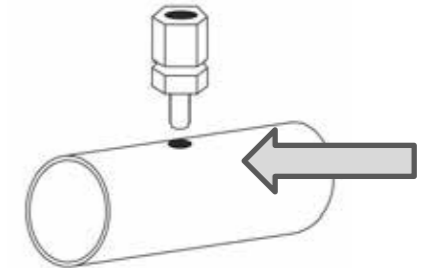

Step 2: For added security it is recommended to use Silicone Sealant (not-supplied) in-between the Pipe Injector and the drilled hole (as shown above). Slowly wind in the Pipe Injector until tight, it is not necessary to over tighten with tools as this may damage the threading on the injector.

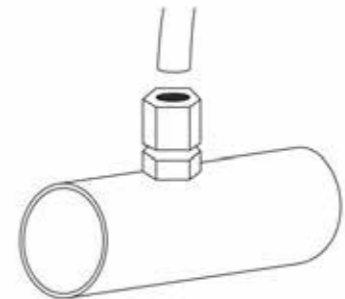

Step 3: Now connect the delivery tubing to the Pipe Injector, turning the compression nut clockwise until hand tight.

Connecting Chemicals

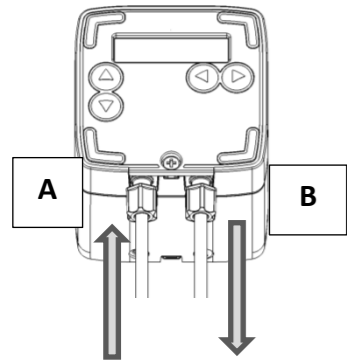

Step 1: Ensure there is no power to the unit; connect the suction tube from the chemical container to **(A)**. Now connect the delivery tube from **(B)** to the drain or injection point.

Flowrate: 100ml/min (3.38fl.oz/min)

Note: Flowrate measured with water and a suction length of 2 metres.

Cleardose Battery

Step 1: Remove the 4 screws on the enclosure and remove the lid by pulling it towards you. Now remove the battery holder to gain access to the batteries. Note that the holder is attached to the main unit so only pull out far enough to gain access to the batteries.

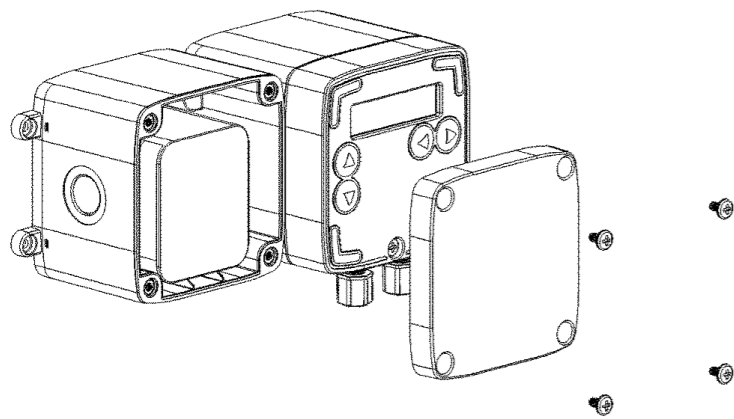

Step 2: Replace the x4 D Cell batteries with a high quality alkaline batteries for optimum performance and longevity. Now replace the battery holder in its enclosure and re-secure the lid.

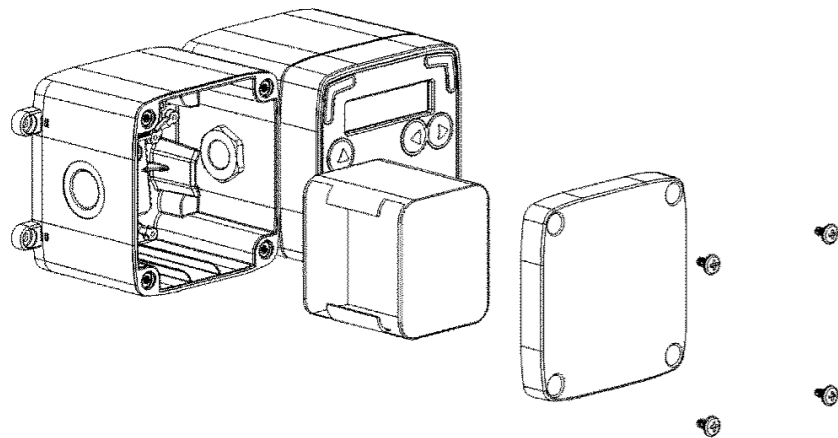

Programing Modes

Step 1: Set your language by pressing the up or down buttons, and then press the right arrow to confirm your selection (a). Now confirm if you would like to set a PIN (b). If 'N' go straight to Step 3.

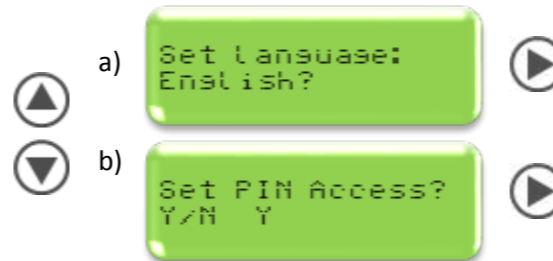

Step 2: If you selected 'Y=Yes' set a unique 4 digit PIN to enable unwanted access (a). Now confirm the pin entered with Y/N? (If 'N=No' is selected you will need to repeat steps 1&2).



Step 3: Set the day of reference i.e Wed=Wednesday and the current time.

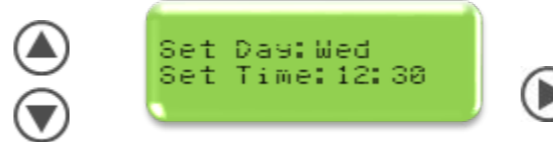

Step 4: (a) Input your first dosing Event by choosing Y=ON, N=OFF using the up and down arrows (please note N will return you to the main menu). Entering the day MTWTSS notice that a dash (-) = no event programed for that day i.e M-W-F-S means no program for Tues,Thurs,Sat. Now set the time for dosing to commence and its duration i.e 01:30=1min 30secs and press the right button to confirm. The event is now stored (b). Press the right arrow again to repeat this process and store another event.

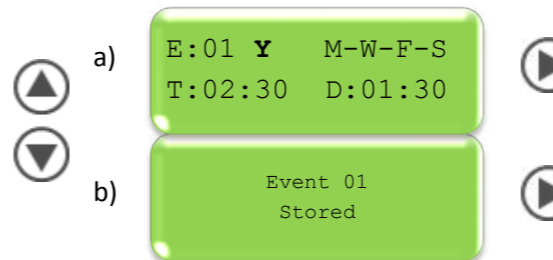

TIP: You can check all your entered events by selecting the event number (this will begin to flash), you can now scroll and check through all events entered. Remember that the 'Y' or 'N' next to the event number indicates ON or OFF for each event.

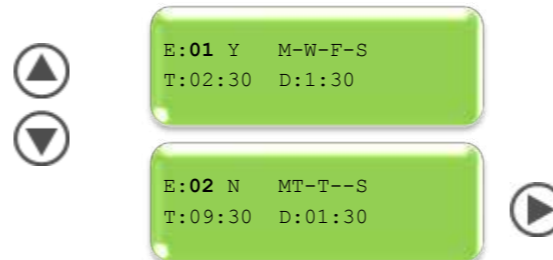

Priming the pumps: Hold down the up ^ arrow until the chemical reaches the injection point.

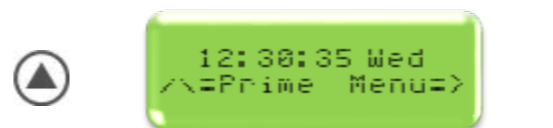

Adjusting Date, Time and Password

Step 1: (a) Enter the menu system by holding down the right button. (b) Once in the menu press and hold the left button for 2 seconds.

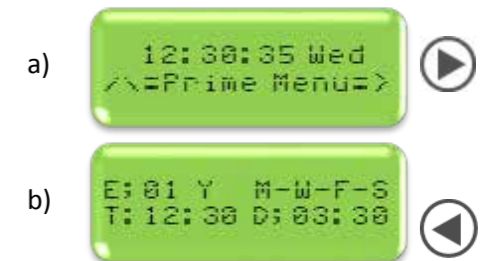

Step 2: (a) Adjust the access code by select Y or N to keep current code (b) Press right to access the time and date settings. Adjust accordingly and press right to get back to the main menu.



Useful Information

The Cleardose pump has a maximum run time of 3 minutes per event. The pump cannot be programed to run longer than this per event.



Warranty

Your product comes as standard with a **1 year warranty from the date of manufacture**, against manufacturing fault or defects and mechanical or electrical breakdown. Please visit our website for full terms and conditions.

WEEE Directive

Please remember to respect the local regulations: hand in the non-working electrical equipment's to an appropriate waste disposal centre. The packaging material is recyclable. Dispose of the packaging in an environmentally friendly manner and make it available for the recyclable material collection-service.



For further information, please call **01484 868 970** or email: support@biobax.co.uk

www.biobax.co.uk

BioBax

Unit 3a, Skelmanthorpe Technology Park,
Standback Way, Skelmanthorpe,
Huddersfield HD8 9GA